



EVERLIGHT ELECTRONICS CO.,LTD.

DATA SHEET

PART NO. : 15-21/Y2C-AP1Q1B/2T

DATE : 2004.03.26

DEPARTMENT : RD3

REVISION : 1.2

RECEIVED			
<input checked="" type="checkbox"/> MASS PRODUCTION			
<input type="checkbox"/> PRELIMINARY			
<input type="checkbox"/> CUSTOMER DESIGN			
DEVICE NUMBER : DSE-191-G01			
PAGE : 13			
CUSTOMER	DESIGNER	CHECKER	APPROVER
	蔡志嘉	/	張正宜

1.2	New data sheet approve	2004.03.26
REV	DESCRIPTION	RELEASE DATE

OFFICE : NO 25,Lane 76,Chung Yang Rd,Sec.3 Tucheng, Taipei 236, Taiwan, R.O.C.

TEL : 886-2-2267-2000,2266-9936 (22 Lines)

FAX : 886-2-2267-6189

<http://www.everlight.com>



Package Type:

SMD For PCB Type

11-21	19-215
12-21	19-215A
12-215	19-217A
15-21	22-21
15-215	23-21
16-213	23-21B
17-21	24-21
17-215	25-21
19-21	27-21
19-21A	42-21

Dominant Wavelength Groups:

According to the difference wavelength to define
None:No definition
A : Standard wavelength definition.
B : Range of wavelength definition is more narrowly than group A.
C : Range of wavelength definition is more narrowly than group A, but the value is different with group B.
F : The wavelength definition in special specification.

The dominant wavelength data did not including ±1nm testing tolerance.

Test Forward Current:

None: 20 mA
Y : 5 mA
Z : 10 mA

Taping Quantity:

- 1: 1000 pcs (Taping)
- 2: 2000 pcs (Taping)
- 3: 3000 pcs (Taping)
- 5: 5000 pcs (Taping)
- C : 1500 pcs (Taping)
- D : 10000 pcs (Taping)

Packing Method :

- A: Reverse-side placement
- B: Reverse-side placement (Anode toward the sprocket hole)
- C: Right-side placement
- D: Right-side placement (Anode toward the sprocket hole)
- T: Top-side placement
- R: Top-side placement (Anode toward the sprocket hole)

19 - 21

/

B

H

C

-

A

N1

P2

M

/

3

T

Emission Color:

- R:Red (λ d:640nm,630nm,625nm)
- S:Sunset Orange (λ d:615nm,605nm)
- Y:Yellow (λ d:595nm,590nm)
- G:Green (λ d:570nm,565nm,560nm,525nm,505nm)
- B:Blue (λ d:470nm)
- W:White x=0.32 y=0.31

The ordinal number that base on diffece electro-optical characteristics within chip.

1,2 7,8,9, A,B.....X,Y,Z

Resin Color:

- C:Water Clear
- W:White Diffused
- D:Diffused

Luminous Intensity Groups:

- | | | |
|-------------------|-----|-------------------|
| C0: 0.28 ... 0.45 | R ⇨ | R1: 112 ... 140 |
| D0: 0.45 ... 0.70 | S ⇨ | R2: 140 ... 180 |
| E0: 0.70 ... 1.1 | T ⇨ | S1: 180 ... 225 |
| F0: 1.1 ... 1.8 | U ⇨ | S2: 225 ... 285 |
| G0: 1.8 ... 2.8 | V ⇨ | T1: 285 ... 360 |
| H0: 2.8 ... 4.5 | W ⇨ | T2: 360 ... 450 |
| J0: 4.5 ... 7.2 | X ⇨ | U1: 450 ... 565 |
| K0: 7.2 ... 11.5 | Y ⇨ | U2: 565 ... 715 |
| L1: 11.5 ... 14.5 | | V1: 715 ... 900 |
| L2: 14.5 ... 18.0 | | V2: 900 ... 1120 |
| M1: 18.0 ... 22.5 | | W1:1120 ... 1420 |
| M2: 22.5 ... 28.5 | | W2:1420 ... 1800 |
| N1: 28.5 ... 36.0 | | X1: 1800 ... 2250 |
| N2: 36.0 ... 45.0 | | X2: 2250 ... 2850 |
| P1: 45.0 ... 57.0 | | Y1: 2850 ... 3600 |
| P2: 57.0 ... 72.0 | | Y2: 3600 ... 4500 |
| Q1: 72.0 ... 90.0 | | |
| Q2: 90.0 ... 112 | | |

Unit:md

The luminous intensity data did not including ±15% testing tolerance.

Forward Voltage Groups:

None: No definition

The VF definition as follows:

Unit:V				
Forward Voltage Group	Bin	Min.	Max.	
C B A	00	1.55	1.75	
	0	1.75	1.95	
	1	1.95	2.15	
	2	2.15	2.35	
	3	2.35	2.55	
M E D	4	2.55	2.75	
	5	2.75	3.05	
	6	3.05	3.35	
	7	3.35	3.65	
	8	3.65	3.95	
N F K R J	9	2.50	2.70	
	10	2.70	2.90	
	11	2.90	3.10	
	12	3.10	3.30	
	13	3.30	3.50	
	14	3.50	3.70	
	P H	15	2.70	2.85
		16	2.85	3.00
		17	3.00	3.15
		18	3.15	3.30

The forward voltage data did not including ±0.1V testing tolerance.

第二代SMD---產線分色規格(Production Line λ d SPEC.) :

Chip		Y1,Y2,Y5		Dom . Wavelength			
Of Groups		Range					
		Bin	Min.	Max.	Unit		
A	B	D3	585.5	588.5	nm	C	(586~590)
		D4	588.5	591.5	nm		
	D5	591.5	594.5	nm	(587~591)		
F		DD0	584	586	nm	D	(585~590)
		DD1	586	588	nm		
		DD2	588	590	nm		
		DD3	590	592	nm		
		DD4	592	594	nm		
Y1,Y2,Y5 ---λp of SPEC.:580~590nm							

Chip		Y3		Dom . Wavelength			
Of Group		Range					
		Bin	Min.	Max.	Unit		
A		D4	588.5	591.5	nm		
		D5	591.5	594.5	nm		
		D6	594.5	597.5	nm		
		D7	597.5	600.5	nm		
λp of SPEC.:593~603nm							

Chip		S1,S2		Dom . Wavelength			
Of Group		Range					
		Bin	Min.	Max.	Unit		
A	B	D7	597.5	600.5	nm		
		D8	600.5	603.5	nm		
		D9	603.5	606.5	nm		
		D10	606.5	609.5	nm		
		D11	609.5	612.5	nm		
F		EE1	603	606	nm		
		EE2	606	609	nm		
λp of SPEC.:605~615nm							

Chip		S3		Dom . Wavelength			
Of Group		Range					
		Bin	Min.	Max.	Unit		
A		E1	605.5	609.5	nm		
		E2	609.5	613.5	nm		
	B	E3	613.5	617.5	nm		
		E4	617.5	621.5	nm		
λp of SPEC.:616~626nm							

七、SMD分光機台校正公差規格：

(M/C Correct tolerance spec.)

TEST條件condition：IF=20mA

Symbol	校正公差規格 Correct tolerance spec.	單位 Unit
IV	IV±5%	mcd
HUE(λ d)	λ d±0.5nm	nm
VF	VF±0.05V	V

EX：19-21 SYGC 校正 Sample --- > IV=30mcd, λ d=570nm, VF=2.1V

校正規格須符合上表公差(Correct spec. need to fit tolerance above table)

$$\left\{ \begin{array}{l} IV=(IV\pm 5\%+IV)\Rightarrow 31.5\text{mcd or } 28.5\text{mcd} \\ \lambda d=(\lambda d\pm 0.5\text{nm}+\lambda d)\Rightarrow 570.5\text{nm or } 569.5\text{nm} \\ VF=(VF\pm 0.05\text{V}+VF)\Rightarrow 2.05\text{V or } 1.95\text{V} \end{array} \right.$$

八、VF規格設定 (Forward voltage spec. setup)：

產線生產設定 / Production Line Setup

Forward Voltage Group		Bin	Min.	Max.
C	A	00	1.55	1.75
		0	1.75	1.95
	B	1	1.95	2.15
		2	2.15	2.35
		3	2.35	2.55
M	D	4	2.55	2.75
		5	2.75	3.05
	E	6	3.05	3.35
		7	3.35	3.65
		8	3.65	3.95
N	K	9	2.50	2.70
		10	2.70	2.90
		11	2.90	3.10
	F	12	3.10	3.30
		13	3.30	3.50
		14	3.50	3.70

PQC & FQA 設定 / PQC & FQA Setup

Forward Voltage Group		Bin	Min.	Max.
C	A	00	1.5	1.8
		0	1.7	2.0
	B	1	1.9	2.2
		2	2.1	2.4
		3	2.3	2.6
M	D	4	2.5	2.8
		5	2.7	3.1
	E	6	3.0	3.4
		7	3.3	3.7
		8	3.6	4.0
N	K	9	2.45	2.75
		10	2.65	2.95
		11	2.85	3.05
	F	12	3.05	3.35
		13	3.25	3.55
		14	3.45	3.75



Technical Data Sheet

1206 Package Chip LED

15-21/Y__C Series *1

Features

- Package in 8mm tape on 7" diameter reel.
- Compatible with automatic placement equipment.
- Compatible with infrared and vapor phase reflow solder process.
- Mono-color type.
- Pb-Free.

Descriptions

- The 15-21 SMD Taping is much smaller than lead frame type components, thus enable smaller board size, higher packing density, reduced storage space and finally smaller equipment to be obtained.
- Besides, lightweight makes them ideal for miniature applications. etc.

Applications

- Automotive: backlighting in dashboard and switch.
- Telecommunication: indicator and backlighting in telephone and fax.
- Flat backlight for LCD, switch and symbol.
- General use.



Device Selection Guide

Part No.	Chip		Lens Color
	Material	Emitted Color	
15-21/Y1C	GaAsP/GaP	Yellow	Water Clear
15-21/Y2C	AlGaInP	Brilliant Yellow	
15-21/Y3C		Yellowish Brown	

*1. The series is included 15-21/Y1C,15-21/Y2C, and 15-21/Y3C.

Package Outline Dimensions

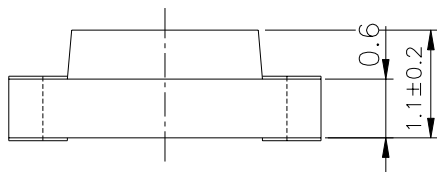
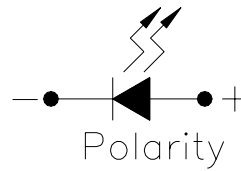
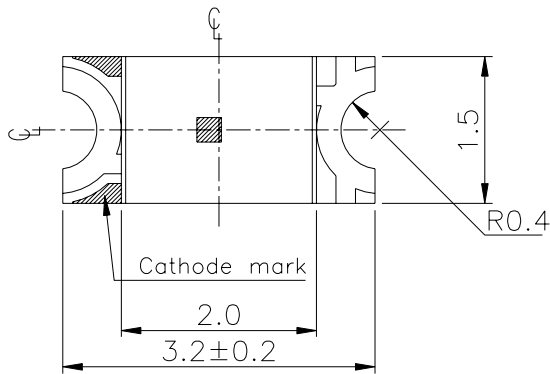

For reflow soldering (propose)

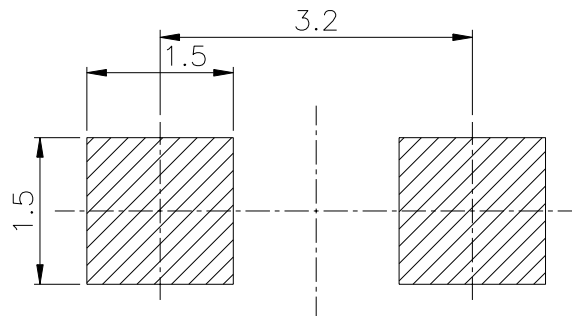
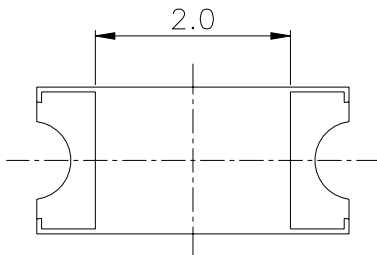

Note: Tolerances Unless Dimension $\pm 0.1\text{mm}$, Unit = mm

Absolute Maximum Ratings (Ta=25°C)

Series	Parameter	Symbol	Rating	Unit
15-21/Y_C Series	Reverse Voltage	V _R	5	V
15-21/Y1C	Forward Current	I _F	30	mA
15-21/Y2C/Y3C			25	
15-21/Y_C Series	Operating Temperature	T _{opr}	-40 ~ +85	°C
15-21/Y_C Series	Storage Temperature	T _{stg}	-40 ~ +90	°C
15-21/Y_C Series	Soldering Temperature	T _{sol}	260 (for 5 seconds)	°C
15-21/Y_C Series	Electrostatic Discharge	ESD	2000	V
15-21/Y1C	Power Dissipation	P _d	100	mW
15-21/Y2C/Y3C			60	
15-21/Y_C Series	Peak Forward Current (Duty 1/10 @1KHz)	I _{FP}	60	mA

Electro-Optical Characteristics (Ta=25°C)

Part No.	Parameter	Symbol	Min.	Typ.	Max.	Unit	Condition
15-21/Y1C	Peak Wavelength	λ_p	----	585	----	nm	If=20mA
15-21/Y2C				591			
15-21/Y3C				598			
15-21/Y1C	Dominant Wavelength	λ_d	----	590	----	nm	
15-21/Y2C				589			
15-21/Y3C				595			
15-21/Y1C	Spectrum Radiation Bandwidth	$\Delta \lambda$	----	35	----	nm	
15-21/Y2C				15			
15-21/Y3C				16			
15-21/Y_C Series	Viewing Angle	$2\theta_{1/2}$	----	130	----	deg	
15-21/Y_C Series	Forward Voltage	V _F	----	2.0	2.4	V	
15-21/Y_C Series	Reverse Current	I _R	----	----	10	μA	V _R =5V

15-21/Y__C Series Explain Of Luminous Intensity:
If=20mA

Part No.	Parameter	Symbol	Typ.	Bin	Min.	Max.	Unit
15-21/Y1C-H0K0	Luminous Intensity	Iv	6	H0	2.8	4.5	mcd
				J0	4.5	7.2	
				K0	7.2	11.5	
15-21/Y2C-N1P2	Luminous Intensity	Iv	50	N1	28.5	36.0	mcd
				N2	36.0	45.0	
				P1	45.0	57.0	
				P2	57.0	72.0	
15-21/Y2C-P1Q2	Luminous Intensity	Iv	75	P1	45.0	57.0	mcd
				P2	57.0	72.0	
				Q1	72.0	90.0	
				Q2	90.0	112	
15-21/Y2C-P2R1	Luminous Intensity	Iv	95	P2	57.0	72.0	mcd
				Q1	72.0	90.0	
				Q2	90.0	112	
				R1	112	140	
15-21/Y2C-Q1R2	Luminous Intensity	Iv	120	Q1	72.0	90.0	mcd
				Q2	90.0	112	
				R1	112	140	
				R2	140	180	

Note:

 The luminous intensity data did not including $\pm 15\%$ testing tolerance.



15-21/Y__C Series Explain Of Luminous Intensity:

I_F=20mA

Part No.	Parameter	Symbol	Typ.	Bin	Min.	Max.	Unit
15-21/Y3C-N1P2	Luminous Intensity	I _v	50	N1	28.5	36.0	mcd
				N2	36.0	45.0	
				P1	45.0	57.0	
				P2	57.0	72.0	
15-21/Y3C-P1Q2	Luminous Intensity	I _v	75	P1	45.0	57.0	mcd
				P2	57.0	72.0	
				Q1	72.0	90.0	
				Q2	90.0	112	
15-21/Y3C-P2R1	Luminous Intensity	I _v	95	P2	57.0	72.0	mcd
				Q1	72.0	90.0	
				Q2	90.0	112	
				R1	112	140	
15-21/Y3C-Q1R2	Luminous Intensity	I _v	120	Q1	72.0	90.0	mcd
				Q2	90.0	112	
				R1	112	140	
				R2	140	180	

Note:The luminous intensity data did not including $\pm 15\%$ testing tolerance.

Typical Electro-Optical Characteristics Curves

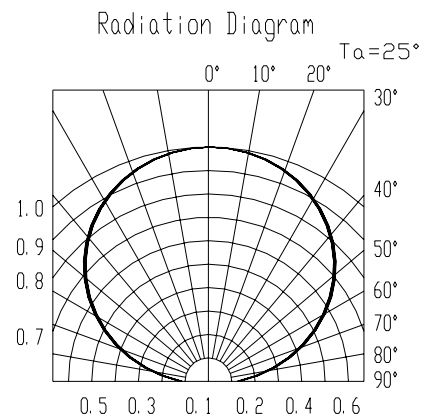
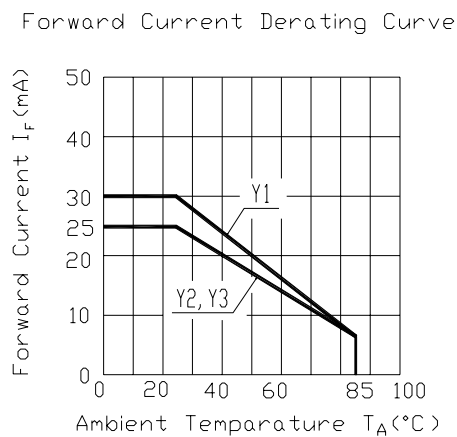
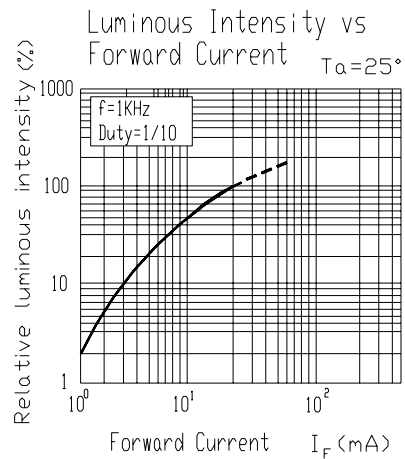
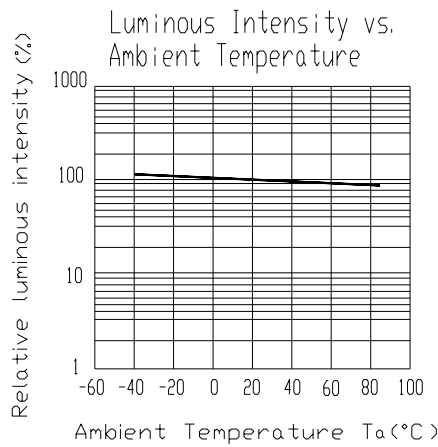
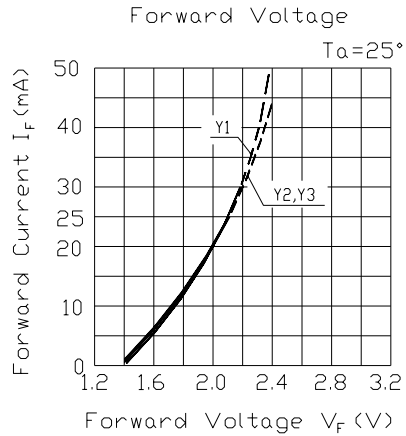
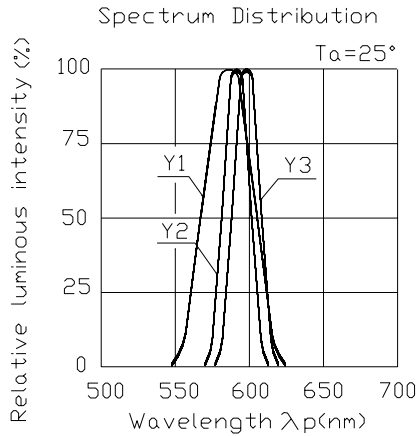

Label explanation

CAT: Luminous Intensity Rank

HUE: Dom. Wavelength Rank

REF: Forward Voltage Rank

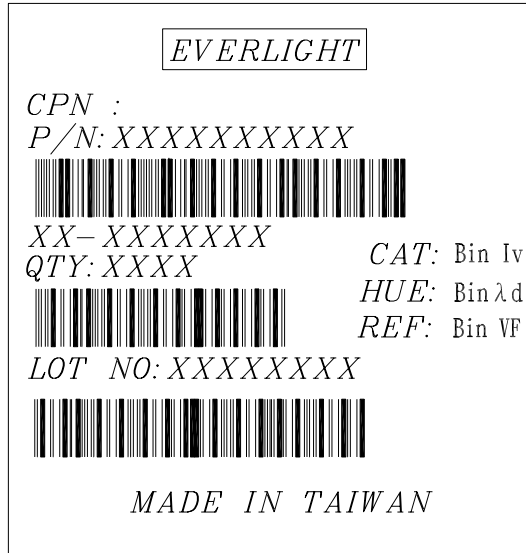

Reel Dimensions

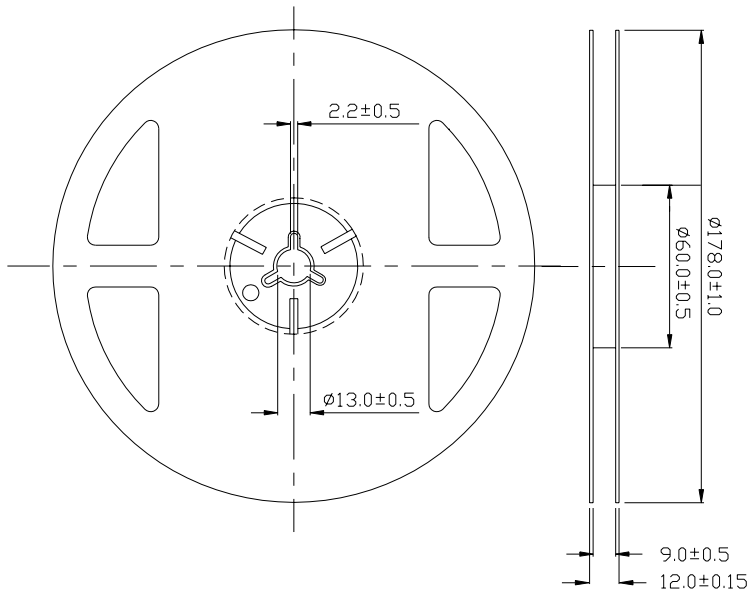

Note: The tolerances unless mentioned is $\pm 0.1\text{mm}$,Unit = mm

Carrier Tape Dimensions: Loaded quantity 2000 PCS per reel

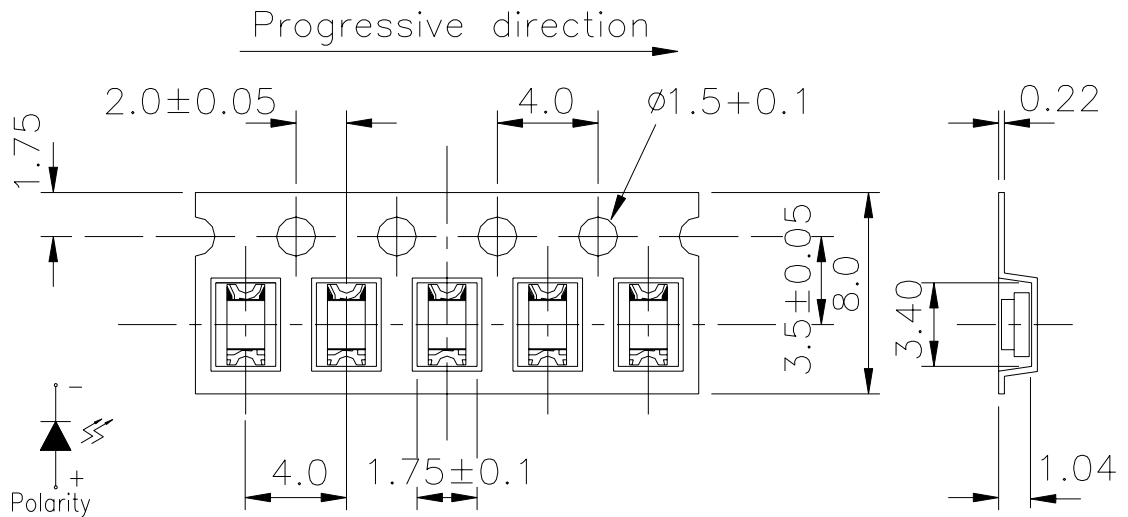

Note: The tolerances unless mentioned is ±0.1mm ,Unit = mm

Moisture Resistant Packaging

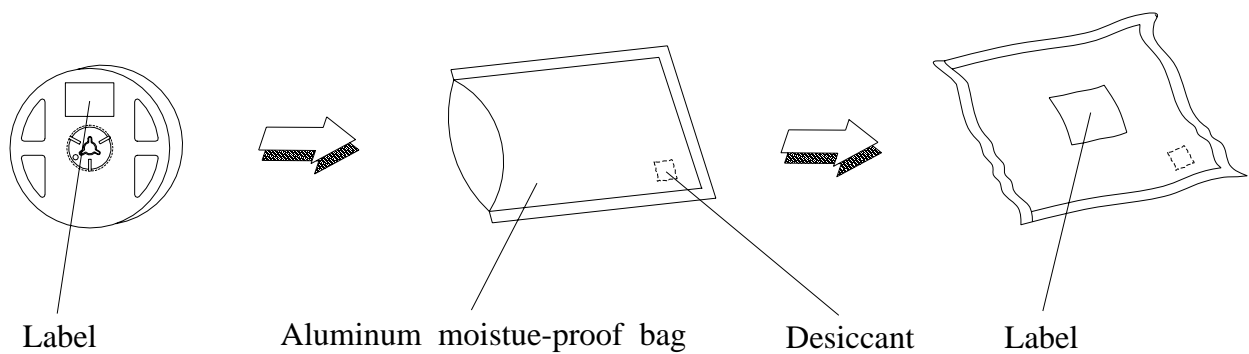

Reliability Test Items And Conditions

The reliability of products shall be satisfied with items listed below.

Confidence level : 90%

LTPD : 10%

No.	Items	Test Condition	Test Hours/Cycles	Sample Size	Ac/Re
1	Reflow Soldering	Temp. : 260°C±5°C Min. 5sec.	6 Min.	22 PCS.	0/1
2	Temperature Cycle	H : +100°C 15min ∫ 5 min L : -40°C 15min	300 Cycles	22 PCS.	0/1
3	Thermal Shock	H : +100°C 5min ∫ 10 sec L : -10°C 5min	300 Cycles	22 PCS.	0/1
4	High Temperature Storage	Temp. : 100°C	1000 Hrs.	22 PCS.	0/1
5	Low Temperature Storage	Temp. : -40°C	1000 Hrs.	22 PCS.	0/1
6	DC Operating Life	IF = 20 mA	1000 Hrs.	22 PCS.	0/1
7	High Temperature / High Humidity	85°C/ 85%RH	1000 Hrs.	22 PCS.	0/1

Precautions For Use

1. Over-current-proof

Customer must apply resistors for protection , otherwise slight voltage shift will cause big current change (Burn out will happen).

2. Storage

- 2.1 Do not open moisture proof bag before the products are ready to use.
- 2.2 Before opening the package, the LEDs should be kept at 30°C or less and 90%RH or less.
- 2.3 The LEDs should be used within a year.
- 2.4 After opening the package, the LEDs should be kept at 30°C or less and 70%RH or less.
- 2.5 The LEDs should be used within 168 hours (7 days) after opening the package.
- 2.6 If the moisture absorbent material (silica gel) has faded away or the LEDs have exceeded the storage time, baking treatment should be performed using the following conditions.
Baking treatment : 60±5°C for 24 hours.

3. Soldering Condition

3.1 Pb-free solder temperature profile

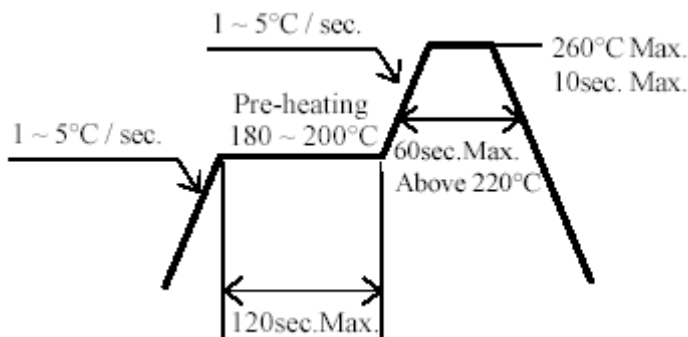

- 3.2 Reflow soldering should not be done more than two times.
- 3.3 When soldering, do not put stress on the LEDs during heating.
- 3.4 After soldering, do not warp the circuit board.

4. Soldering Iron

Each terminal is to go to the tip of soldering iron temperature less than 280°C for 3 seconds within once in less than the soldering iron capacity 25W. Leave two seconds and more intervals, and do soldering of each terminal. Be careful because the damage of the product is often started at the time of the hand solder.

5.Repairing

Repair should not be done after the LEDs have been soldered. When repairing is unavoidable, a double-head soldering iron should be used (as below figure). It should be confirmed beforehand whether the characteristics of the LEDs will or will not be damaged by repairing.

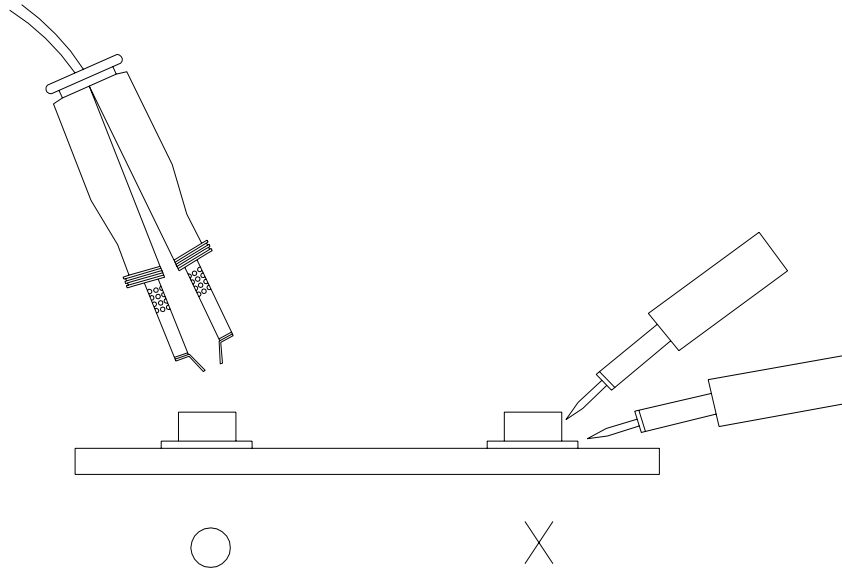

EVERLIGHT ELECTRONICS CO., LTD.
Office: No 25, Lane 76, Sec 3, Chung Yang Rd,
Tucheng, Taipei 236, Taiwan, R.O.C

Tel: 886-2-2267-2000, 2267-9936
Fax: 886-2267-6244, 2267-6189, 2267-6306
<http://www.everlight.com>