



Technical Data Sheet

0603 Package Chip LED(0.6mm Height)

19-213/S3C-AN2P2B/3T

Features

- Package in 8mm tape on 7" diameter reel.
- Compatible with automatic placement equipment.
- Compatible with infrared and vapor phase reflow solder process.
- Mono-color type.
- Pb-free.
- The product itself will remain within RoHS complaint version

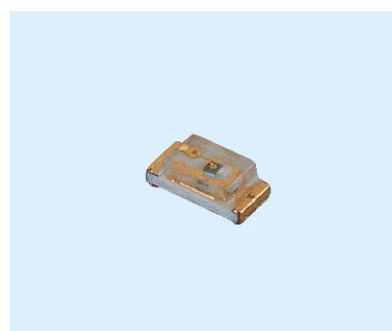

Descriptions

- The 19-213 SMD Taping is much smaller than lead frame type components, thus enable smaller board size, higher packing density, reduced storage space and finally smaller equipment to be obtained.
- Besides, lightweight makes them ideal for miniature applications. etc.

Applications

- Backlighting in dashboard and switch.
- Telecommunication: indicator and backlighting in telephone and fax.
- Flat backlight for LCD, switch and symbol.
- General use.

Device Selection Guide

Part No.	Chip		Lens Color
	Material	Emitted Color	
19-213/S3C-AN2P2B/3T	AlGaInP	Reddish Orange	Water Clear

Package Outline Dimensions

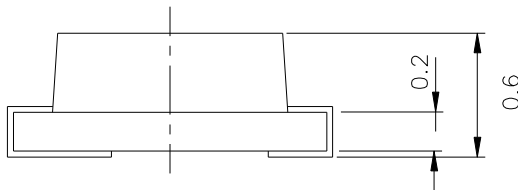
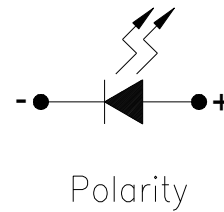
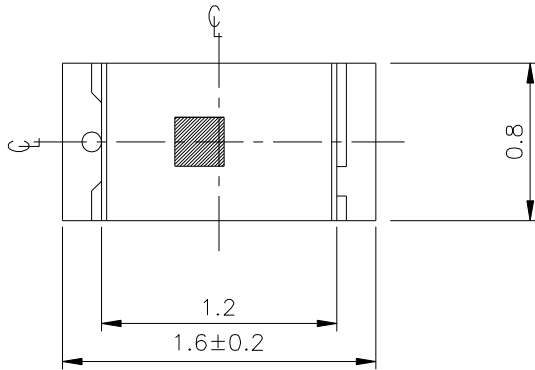

For reflow soldering (Propose)

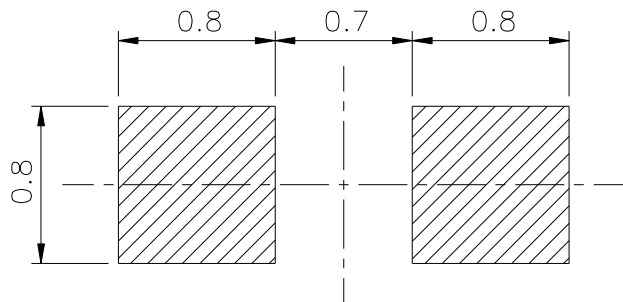
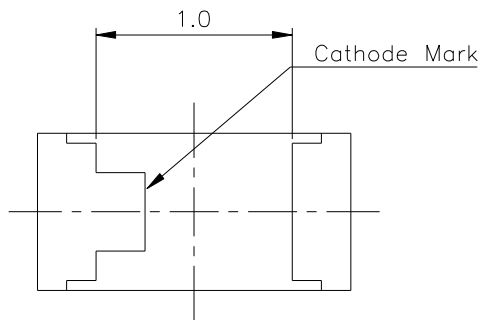

Note: Tolerances Unless Dimension is $\pm 0.1\text{mm}$, Unit = mm

19-213/S3C-AN2P2B/3T
Absolute Maximum Ratings (Ta=25°C)

Parameter	Symbol	Rating	Unit
Reverse Voltage	V _R	5	V
Forward Current	I _F	25	mA
Peak Forward Current (Duty 1/10 @ 1KHz)	I _{FP}	60	mA
Power Dissipation	P _d	60	mW
Electrostatic Discharge(HBM)	ESD	2000	V
Operating Temperature	Topr	-40 ~ +85	°C
Storage Temperature	Tstg	-40~ +90	°C
Soldering Temperature	Tsol	Reflow Soldering : 260 °C for 10 sec. Hand Soldering : 350 °C for 3 sec.	

Electro-Optical Characteristics (Ta=25°C)

Parameter	Symbol	Min.	Typ.	Max.	Unit	Condition
Luminous Intensity	I _v	36.0	-----	72.0	mcd	I _F =20mA
Viewing Angle	2θ 1/2	-----	120	-----	deg	
Peak Wavelength	λ _p	-----	621	-----	nm	
Dominant Wavelength	λ _d	605.5	-----	621.5	nm	
Spectrum Radiation Bandwidth	△λ	-----	18	-----	nm	
Forward Voltage	V _F	1.75	-----	2.35	V	
Reverse Current	I _R	-----	-----	10	μA	V _R =5V

Notes:

- 1. Tolerance of Luminous Intensity ±10%**
- 2. Tolerance of Dominant Wavelength ±1nm**
- 3. Tolerance of Forward Voltage ±0.1V**

19-213/S3C-AN2P2B/3T
Bin Range Of Dom. Wavelength

Group	Bin	Min	Max	Unit	Condition
A	E1	605.5	609.5	nm	I _F =20mA
	E2	609.5	613.5		
	E3	613.5	617.5		
	E4	617.5	621.5		

Bin Range Of Luminous Intensity

Bin	Min	Max	Unit	Condition
N2	36.0	45.0	mcd	I _F =20mA
P1	45.0	57.0		
P2	57.0	72.0		

Bin Rang Of Forward Voltage

Group	Bin	Min	Max	Unit	Condition
B	0	1.75	1.95	V	I _F =5mA
	1	1.95	2.15		
	2	2.15	2.35		

Notes:

1. Tolerance of Luminous Intensity $\pm 10\%$
2. Tolerance of Dominant Wavelength $\pm 1\text{nm}$
3. Tolerance of Forward Voltage $\pm 0.1\text{V}$

Typical Electro-Optical Characteristics Curves

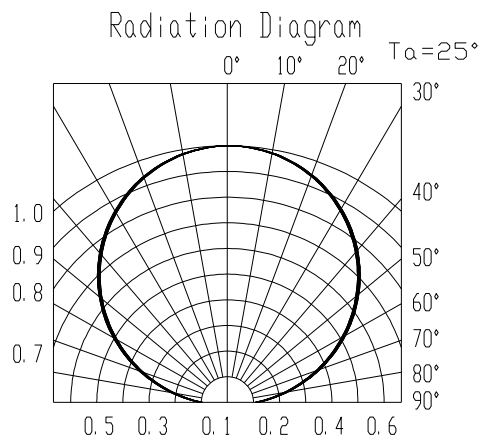
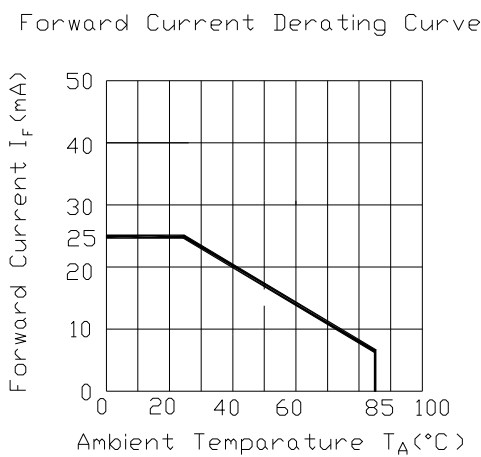
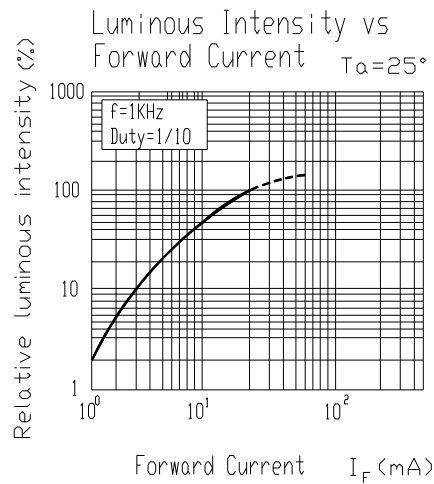
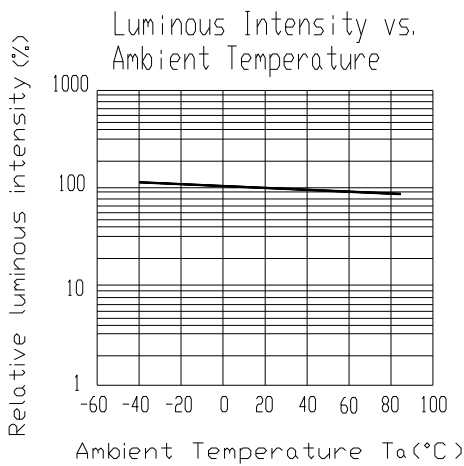
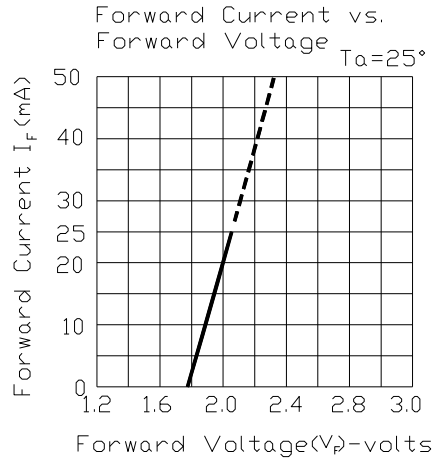
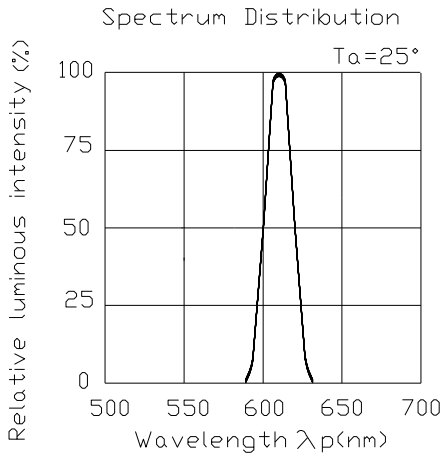

19-213/S3C-AN2P2B/3T

Label explanation

CAT: Luminous Intensity Rank

HUE: Dom. Wavelength Rank

REF: Forward Voltage Rank

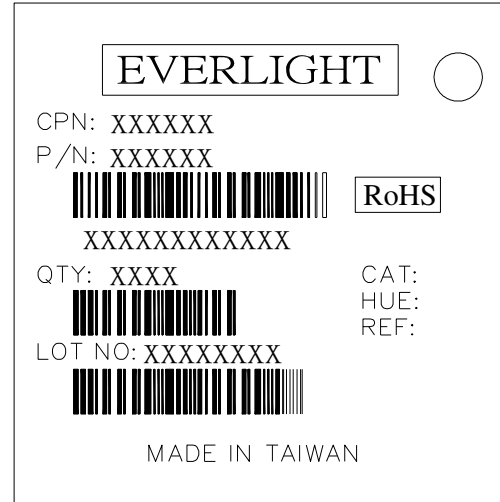

Reel Dimensions

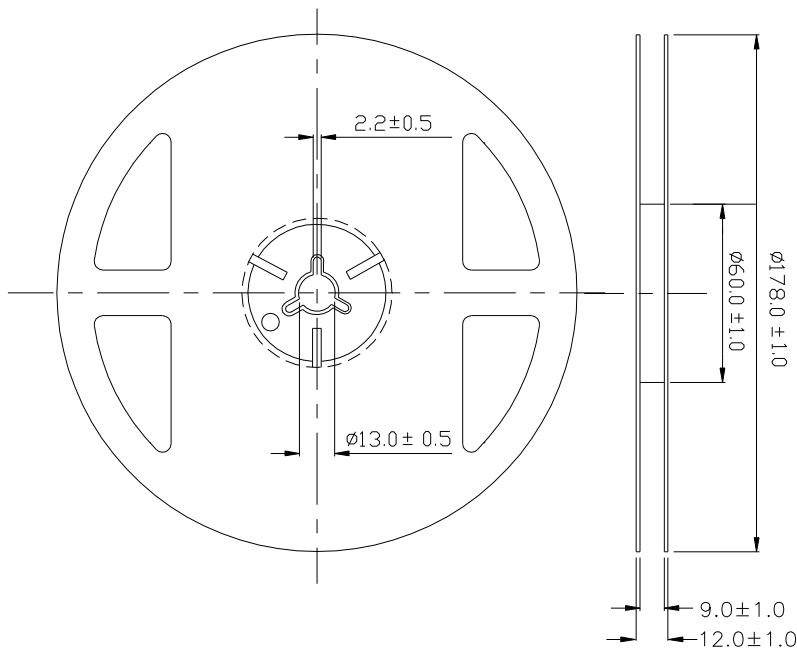

Note: The tolerances unless mentioned are ±0.1, Unit = mm.

Loaded quantity 3000 PCS per reel

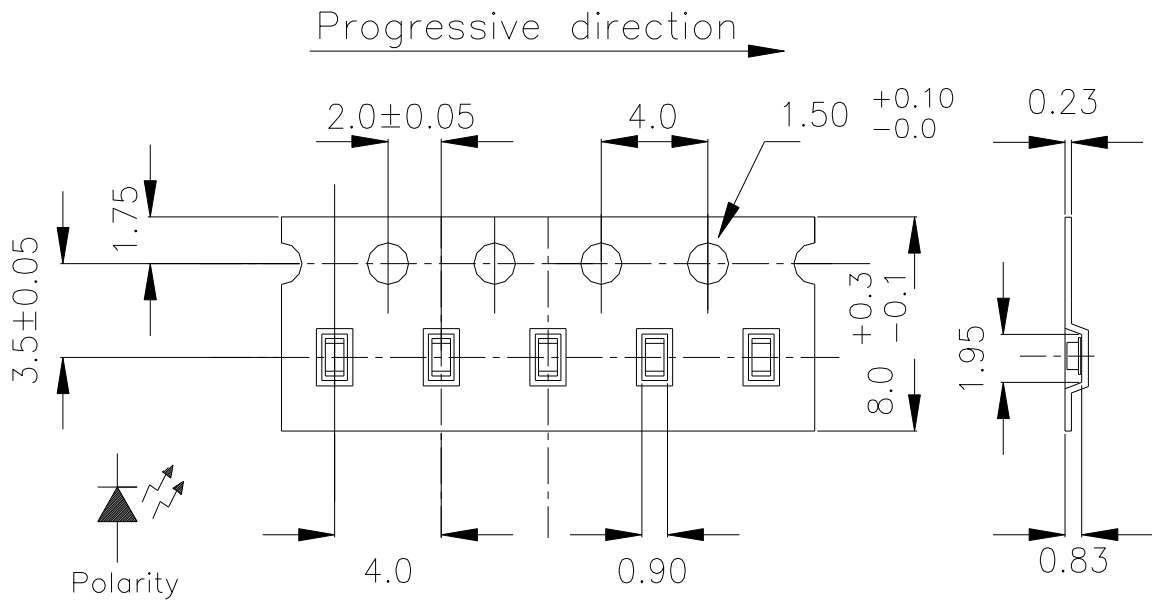

Note: Tolerances Unless Dimension is ±0.1mm, Unit = mm

Moisture Resistant Packaging

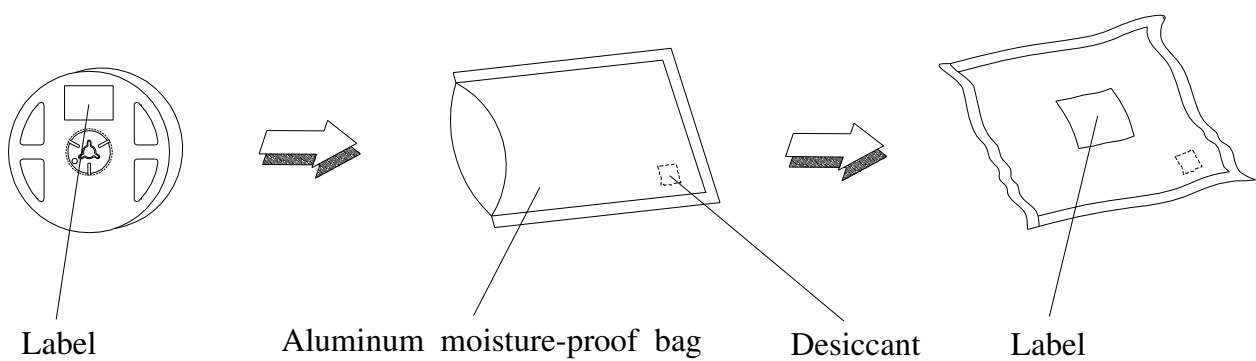

19-213/S3C-AN2P2B/3T
Reliability Test Items And Conditions

The reliability of products shall be satisfied with items listed below.

Confidence level : 90 %

LTPD : 10 %

No.	Items	Test Condition	Test Hours/Cycles	Sample Size	Ac/Re
1	Reflow Soldering	Temp. : 260°C ±5°C Min. 5 sec.	6 min.	22 Pcs.	0/1
2	Temperature Cycle	H : +100°C 15min. § 5 min. L : -40°C 15min.	300 Cycles	22 Pcs.	0/1
3	Thermal Shock	H : +100°C 5min. § 10 sec. L : -10°C 5min.	300 Cycles	22 Pcs.	0/1
4	High Temperature Storage	Temp. : 100°C	1000 Hrs.	22 Pcs.	0/1
5	Low Temperature Storage	Temp. : -40°C	1000 Hrs.	22 Pcs.	0/1
6	DC Operating Life	I _F = 20 mA	1000 Hrs.	22 Pcs.	0/1
7	High Temperature / High Humidity	85°C/R.H85%	1000 Hrs.	22 Pcs.	0/1

Precautions For Use

1. Over-current-proof

Customer must apply resistors for protection , otherwise slight voltage shift will cause big current change (Burn out will happen).

2. Storage

2.1 Do not open moisture proof bag before the products are ready to use.

2.2 Before opening the package: The LEDs should be kept at 30°C or less and 90%RH or less.

2.3 After opening the package: The LED's floor life is 1 year under 30 deg C or less and 60% RH or less.

If unused LEDs remain, it should be stored in moisture proof packages.

2.4 If the moisture absorbent material (silica gel) has faded away or the LEDs have exceeded the storage time, baking treatment should be performed using the following conditions.

Baking treatment : 60±5°C for 24 hours.

3. Soldering Condition

3.1 Pb-free solder temperature profile

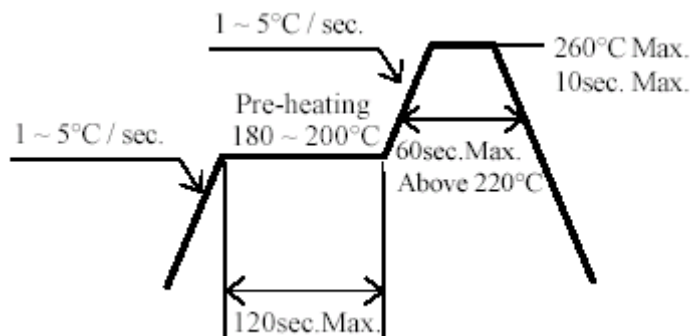

3.2 Reflow soldering should not be done more than two times.

3.3 When soldering, do not put stress on the LEDs during heating.

3.4 After soldering, do not warp the circuit board.

4. Soldering Iron

Each terminal is to go to the tip of soldering iron temperature less than 350°C for 3 seconds within once in less than the soldering iron capacity 25W. Leave two seconds and more intervals, and do soldering of each terminal. Be careful because the damage of the product is often started at the time of the hand solder.

5.Repairing

Repair should not be done after the LEDs have been soldered. When repairing is unavoidable, a double-head soldering iron should be used (as below figure). It should be confirmed beforehand whether the characteristics of the LEDs will or will not be damaged by repairing.

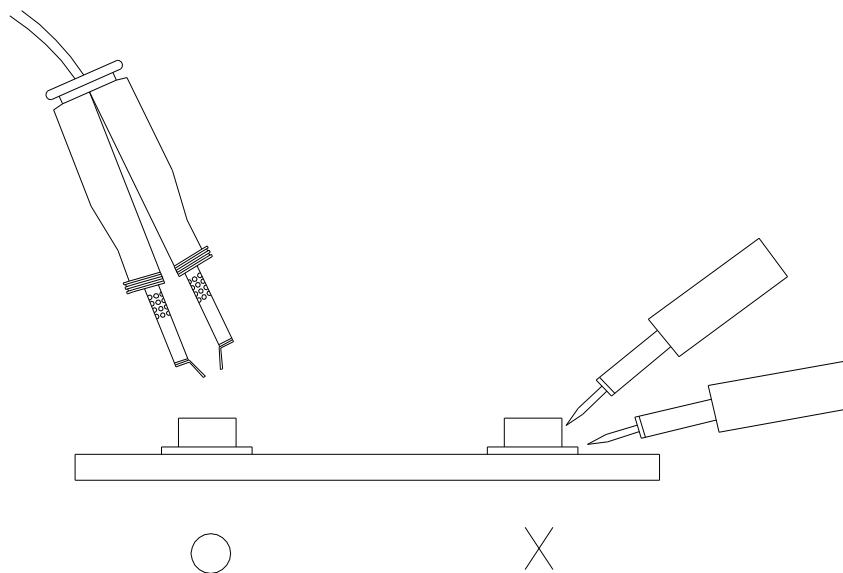

EVERLIGHT ELECTRONICS CO., LTD.

Office: No 25, Lane 76, Sec 3, Chung Yang Rd,
Tucheng, Taipei 236, Taiwan, R.O.C

Tel: 886-2-2267-2000, 2267-9936

Fax: 886-2267-6244, 2267-6189, 2267-6306
<http://www.everlight.com>