

Technical Data Sheet

1206 Package Chip LED

15-21-Y2C-A0P1Q2B0E-2T-AM

Lead (Pb) Free Product - RoHS Compliant



Feature

- RoHS compliant.
- Chip LED package.
- Colorless clear resin.
- Wide viewing angle 130°.
- Brightness: 45 to 112 mcd at 20mA.
- Qualification according to AEC-Q101.
- Precondition: Bases on JEDEC J-STD 020 Level 2.
- Automotive reflow profile (IR reflow or wave soldering))

Applications

- Automotive backlighting or indicator: Dashboard, switch, audio and video equipments... etc.
- Backlight: LCD, switches, symbol, mobile phone and illuminated advertising.
- Display for indoor and outdoor application.
- Ideal for coupling into light guides.
- Substitution of traditional light.
- Optical indicator.
- General applications.

Device Selection Guide

Chip	Emitted Color	Resin Color
Material		
AlGaInP	Brilliant Yellow	Water Clear

Technical Data Sheet**1206 Package Chip LED****15-21-Y2C-A0P1Q2B0E-2T-AM****Absolute Maximum Ratings (Ta=25°C)**

Parameter	Symbol	Rating	Unit
Reverse Voltage	V _R	12	V
Forward Current	I _F	30	mA
Peak Forward Current (Duty 1/10 @1KHz)	I _{FP}	60	mA
Power Dissipation	P _d	60	mW
Junction Temperature	T _j	125	°C
Operating Temperature	T _{opr}	-40 ~ +100	°C
Storage Temperature	T _{stg}	-40 ~ +110	°C
Thermal resistance	R _{th J-A}	800	K/W
	R _{th J-S}	450	K/W
Soldering Temperature	T _{sol}	Reflow Soldering : 260 °C for 30 sec. Hand Soldering : 350 °C for 3 sec.	
ESD (Classification acc. AEC Q101)	ESD _{HBM}	2000	V
	ESD _{MM}	200	V

Technical Data Sheet
1206 Package Chip LED
15-21-Y2C-A0P1Q2B0E-2T-AM
Electro-Optical Characteristics (Ta=25°C)

Parameter	Symbol	Min.	Typ.	Max.	Unit	Condition
Luminous Intensity	I_v	45	-----	112	mcd	$I_F=20mA$
Viewing Angle	$2\theta_{1/2}$	-----	130	-----	deg	$I_F=20mA$
Peak Wavelength	λ_p	-----	591	-----	nm	$I_F=20mA$
Dominant Wavelength	λ_d	585.5	-----	594.5	nm	$I_F=20mA$
Spectrum Radiation Bandwidth	$\Delta\lambda$	-----	15	-----	nm	$I_F=20mA$
Forward Voltage	V_F	1.75	-----	2.35	V	$I_F=20mA$
Reverse Current	I_R	-----	-----	10	μA	$V_R=12V$
Temperature coefficient of λ_p	TC_{λ_p}	-----	0.06	-----	nm/K	$I_F=20mA$
Temperature coefficient of λ_d	TC_{λ_d}	-----	0.4	-----	nm/K	$I_F=20mA$
Temperature coefficient of V_F	TC_V	-----	-2.3	-----	mV/K	$I_F=20mA$

Note:

Tolerance of Luminous Intensity: $\pm 11\%$

Tolerance of Dominant Wavelength: $\pm 1nm$

Tolerance of Forward Voltage: $\pm 0.1V$



Technical Data Sheet

1206 Package Chip LED

15-21-Y2C-A0P1Q2B0E-2T-AM

Bin Range of Luminous Intensity

Bin Code	Min.	Max.	Unit	Condition
P1	45	56	mcd	I _F =20mA
P2	56	71		
Q1	71	90		
Q2	90	112		

Note

Tolerance of Luminous Intensity : $\pm 11\%$

Bin Range of Dominant Wavelength

Bin Code	Min.	Max.	Unit	Condition
D3	585.5	588.5	nm	I _F =20mA
D4	588.5	591.5		
D5	591.5	594.5		

Note:

Tolerance of Dominant Wavelength: $\pm 1\text{nm}$

Technical Data Sheet

1206 Package Chip LED

15-21-Y2C-A0P1Q2B0E-2T-AM

Typical Electro-Optical Characteristics Curves

Typical curve of spectral distribution:

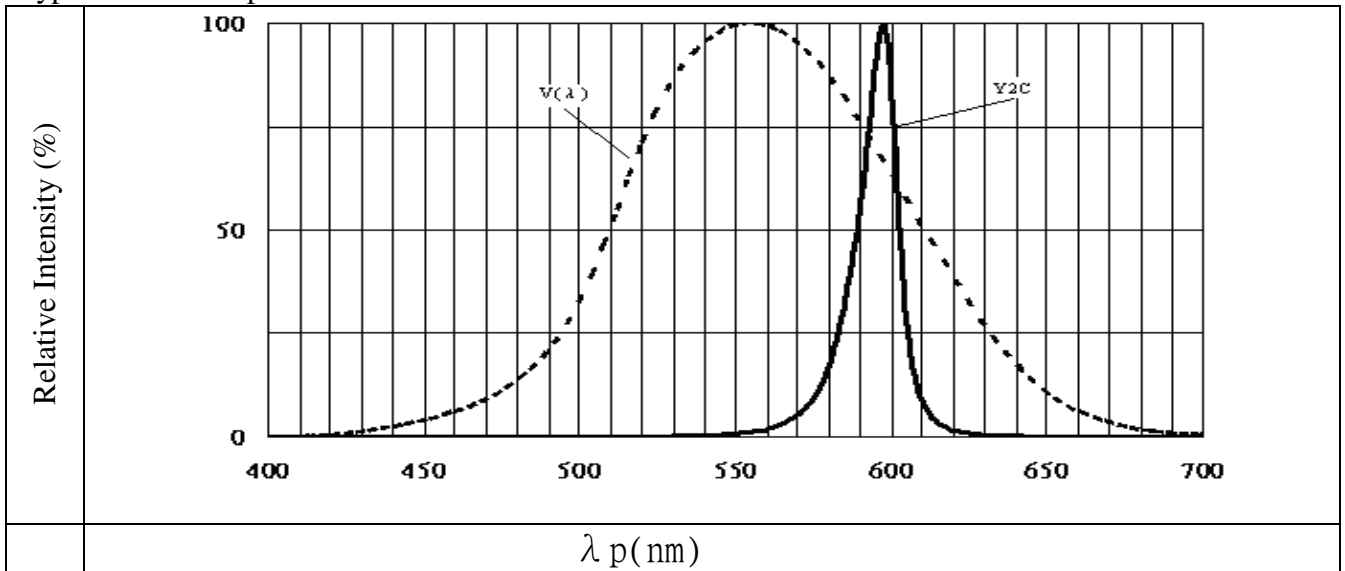

Note: $V(\lambda)$ =Standard eye response curve

Diagram characteristics of radiation

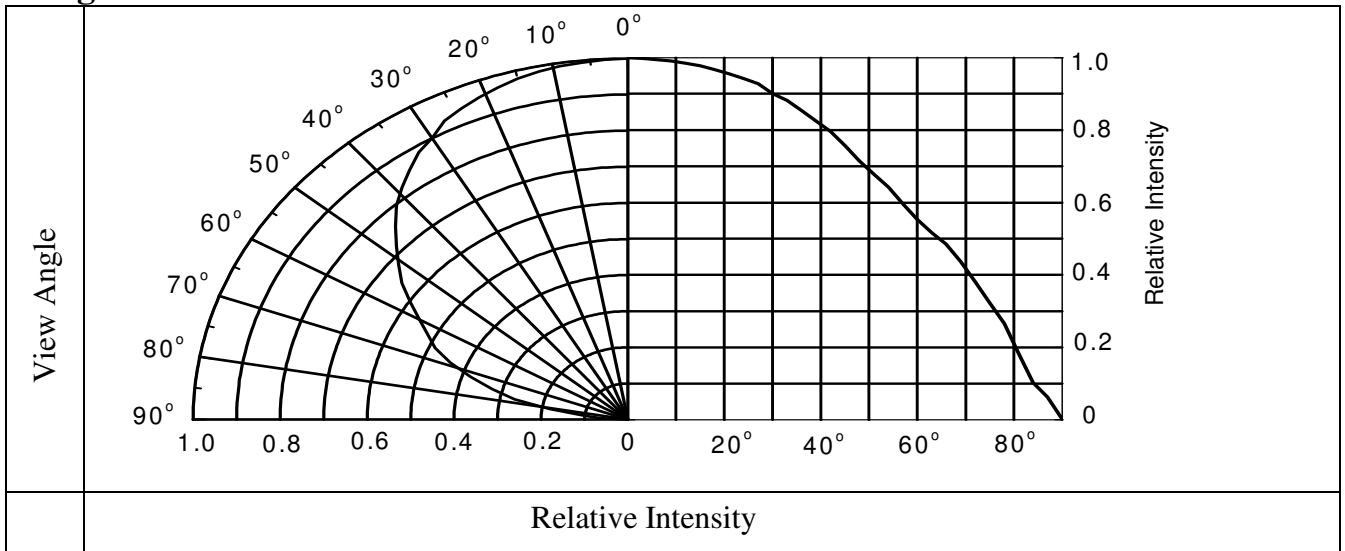

Technical Data Sheet

1206 Package Chip LED

15-21-Y2C-A0P1Q2B0E-2T-AM

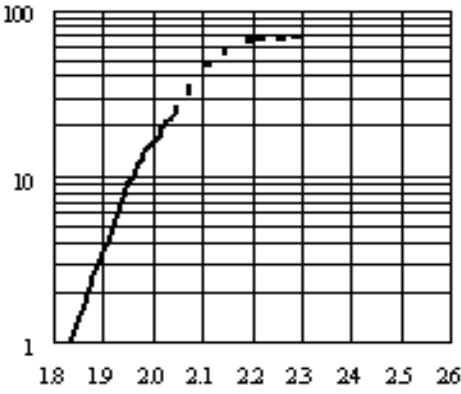
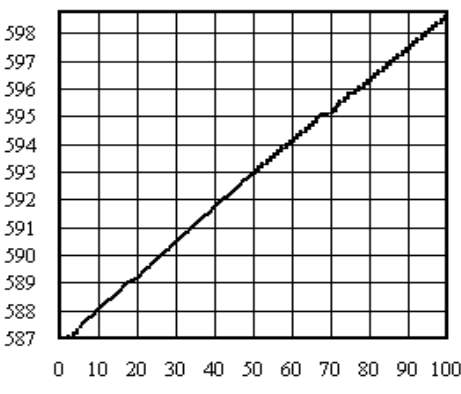
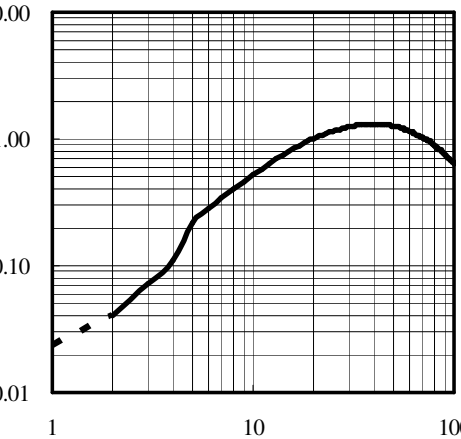
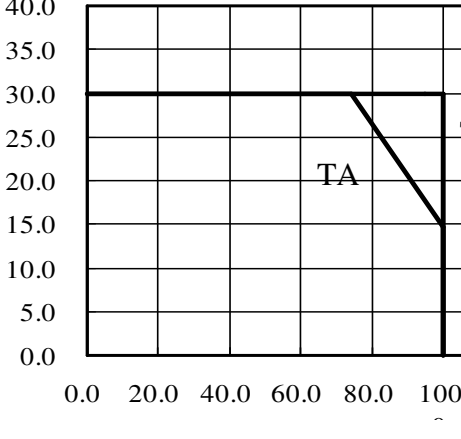
Forward Current vs. Forward Voltage (Ta=25°C)		Dominant Wavelength vs. Forward Current (Ta=25°C)	
Forward Current (mA)		Dominant Wavelength (nm)	
	Forward Voltage (V)		Forward Current (mA)
Relative Luminous Intensity vs. Forward Current (Ta=25°C)		Forward current vs. Ambient and Solder Temperature	
Relative Luminous Intensity		Forward Current (mA)	
	Forward Current (mA)		Temperature (°C)

Technical Data Sheet

1206 Package Chip LED

15-21-Y2C-A0P1Q2B0E-2T-AM

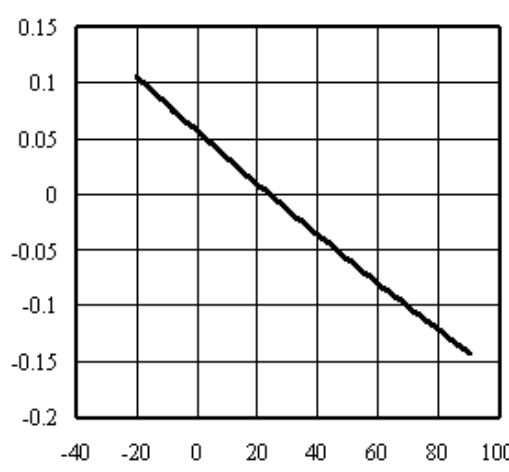
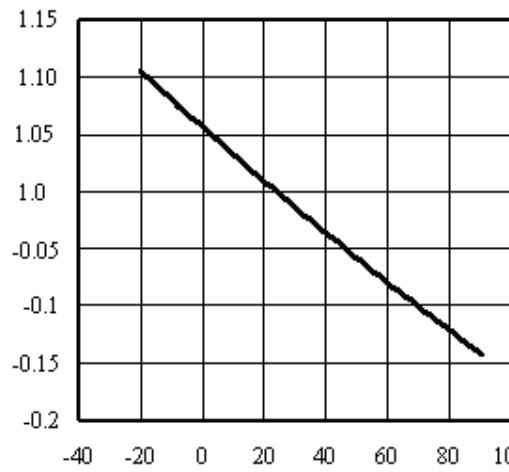
Relative Luminous Intensity vs. Junction Temperature		Relative Forward Voltage vs. Junction Temperature	
Relative Luminous Intensity		Relative Forward Voltage	
	Junction Temperature (°C)		Junction Temperature (°C)
Note: $f(T_j) = I_v - I_v(25^\circ\text{C}); I_F = 20\text{mA}$		Note: $\Delta V_F = V_F / V_F(25^\circ\text{C}) = f(T_j); I_F = 20\text{mA}$	

Technical Data Sheet

1206 Package Chip LED

15-21-Y2C-A0P1Q2B0E-2T-AM

Package Dimension

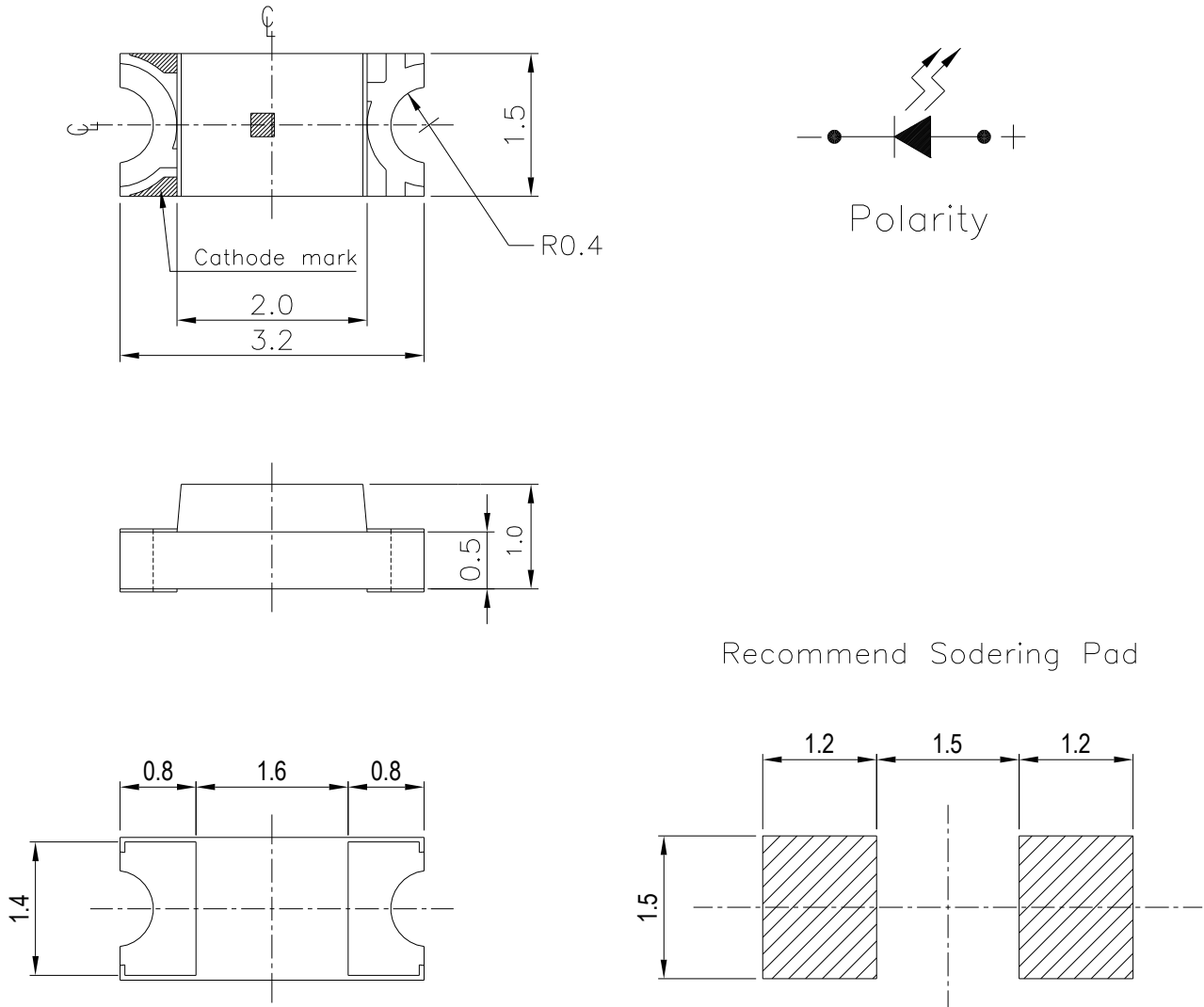

Note: Tolerances unless mentioned ± 0.1 mm. Unit = mm

Technical Data Sheet

1206 Package Chip LED

15-21-Y2C-A0P1Q2B0E-2T-AM

Carrier Tape Dimensions: Loaded Quantity 2000 pcs Per Reel

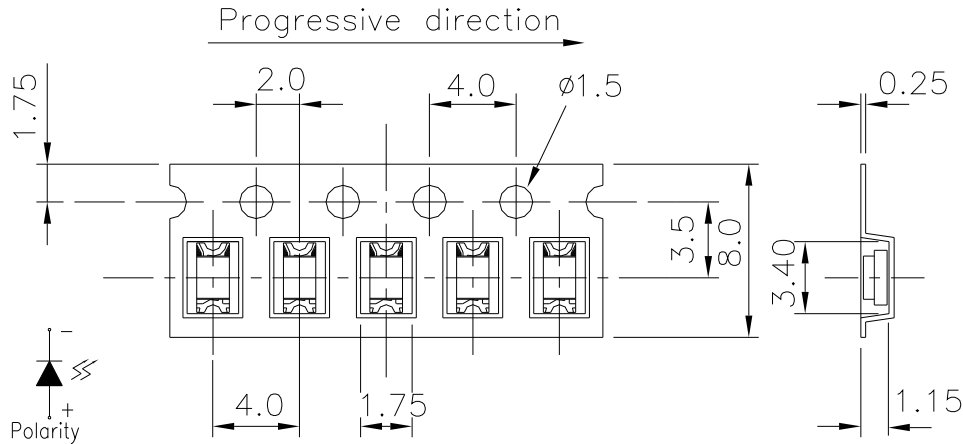

Note: Tolerances unless mentioned $\pm 0.1\text{mm}$. Unit = mm

Label Explanation

- CPN: Customer's Product Number
- P/N: Product Number
- QTY: Packing Quantity
- CAT: Luminous Intensity Rank
- HUE: Dom. Wavelength Rank
- REF: Forward Voltage Rank
- LOT No: Lot Number



Technical Data Sheet

1206 Package Chip LED

15-21-Y2C-A0P1Q2B0E-2T-AM

Reel Dimensions

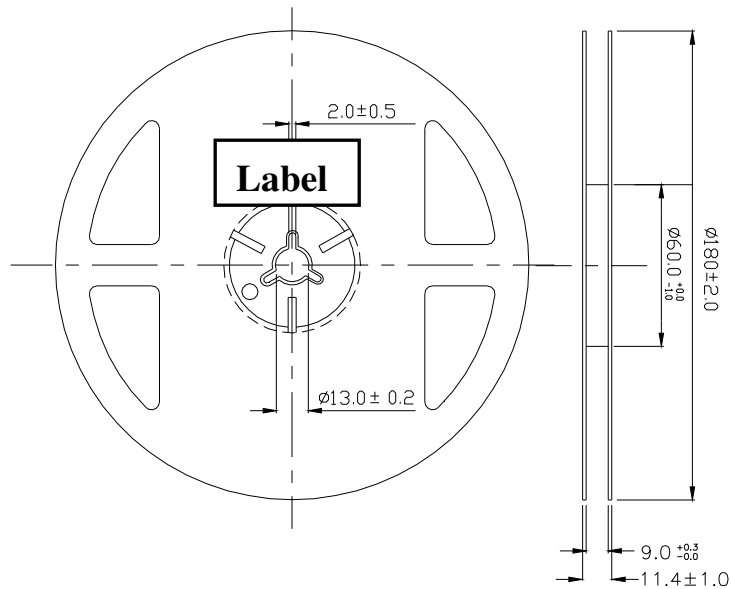

Note: Unit = mm

Moisture Resistant Packaging Process and Materials

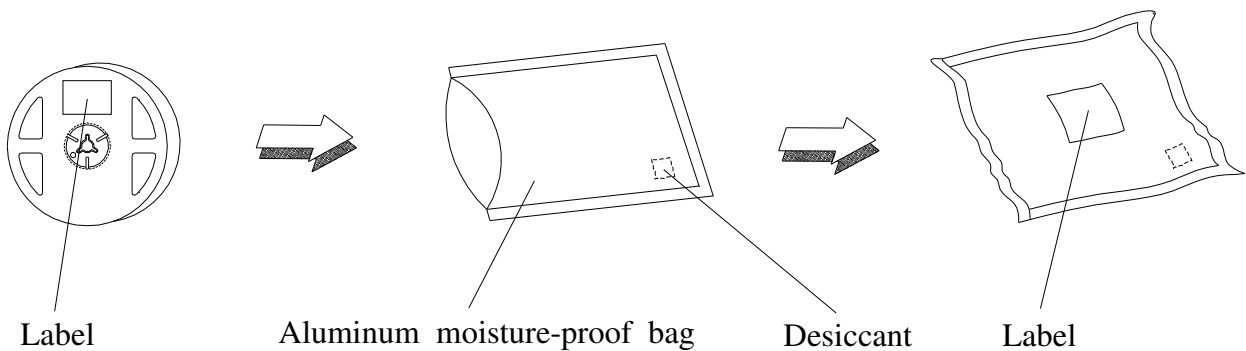

Technical Data Sheet

1206 Package Chip LED

15-21-Y2C-A0P1Q2B0E-2T-AM

Precautions for Use

1. Soldering Condition (Reference: IPC/JEDEC J-STD-020D)

a. IR reflow

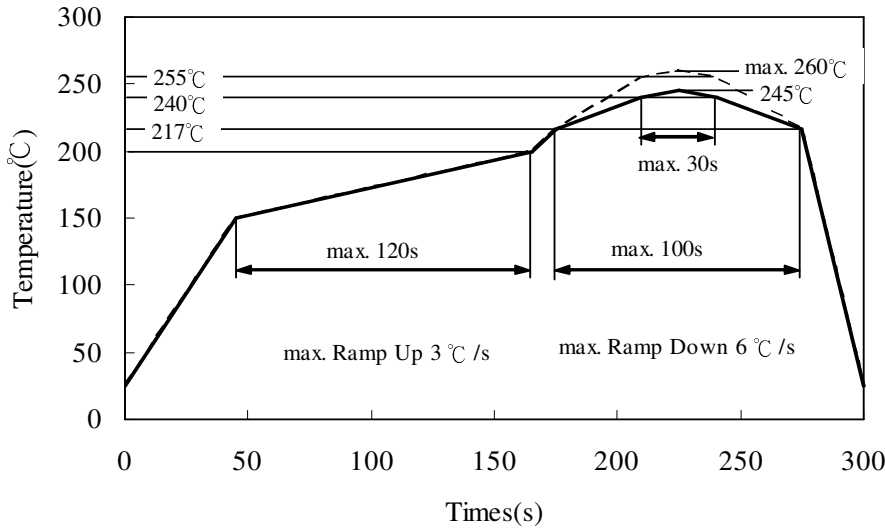

b. Wave soldering reflow

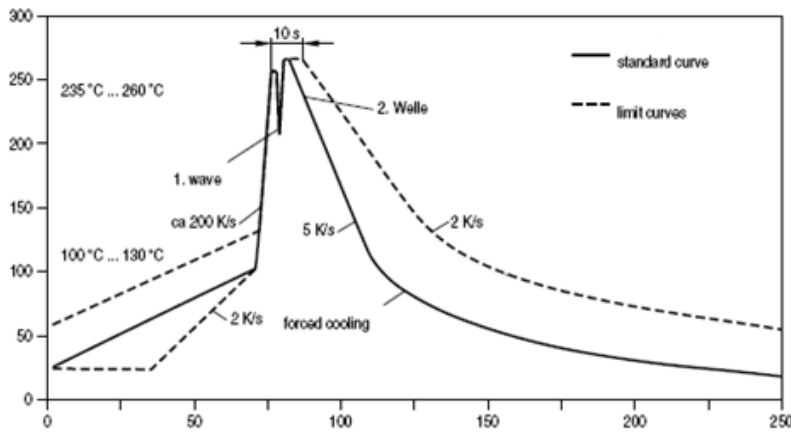

Technical Data Sheet**1206 Package Chip LED****15-21-Y2C-A0P1Q2B0E-2T-AM**

(B) Recommend soldering pad

Recommend Sodering Pad

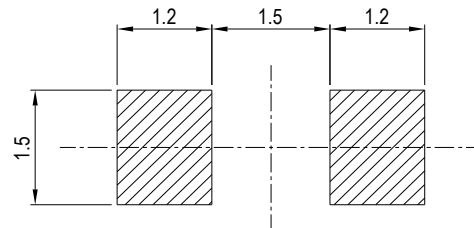
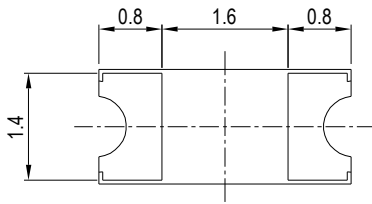

Note: Tolerances unless mentioned ± 0.1 mm. Unit = mm

2. Current limiting

A resistor should be used to limit current spikes that can be caused by voltage fluctuations. Otherwise damage could occur.

3. Storage

3.1 Moisture proof bag should only be opened immediately prior to usage.

3.2 Environment should be less than 30°C and 60% RH when moisture proof bag is opened.

3.3 After opening the package MSL Conditions stated on page 1 of this spec should not be exceeded.

3.4 If the moisture sensitivity card indicates higher than acceptable moisture, the component should be baked at min. 60deg +/-5deg for 24 hours.

4. Iron Soldering

Hand soldering is not recommended for regular production. These guidelines are for rework only. Soldering iron tip should contact each terminal no more than 3 sec at 350°C, using soldering iron with nominal power less than 25W. Allow min. 2 sec. between soldering intervals.

5. Usage

Do not exceed the values given in this specification.

Application Restrictions

1. High reliability applications such as military/aerospace, automotive safety/security systems, and medical equipment may require different product. If you have any concerns, please contact Everlight before using this product in your application. This specification guarantees the quality and performance of the product as an individual component. Do not use this product beyond the specification described in this document.



Technical Data Sheet

1206 Package Chip LED

15-21-Y2C-A0P1Q2B0E-2T-AM

Revision History:

Rev.	Modified date	File modified contents
1	2011/6/30	New Spec