



Technical Data Sheet

Reverse Package Chip LEDs

23-21UBGC/TR8

Features

- Package in 8mm tape on 7" diameter reel.
- Compatible with automatic placement equipment.
- Compatible with infrared and vapor phase reflow solder process.
- Mono-color type.

Descriptions

- The 23-21 SMD Taping is much smaller than lead frame type components, thus enable smaller board size, higher packing density, reduced storage space and finally smaller equipment to be obtained.
- Besides, lightweight makes them ideal for miniature applications. etc.

Applications

- Automotive: backlighting in dashboard and switch.
- Telecommunication: indicator and backlighting in telephone and fax.
- Flat backlight for LCD, switch and symbol.
- General use.



Device Selection Guide

Chip		Lens Color
Material	Emitted Color	
InGaN/SiC	Super Blue Green	Water Clear

Package Outline Dimensions

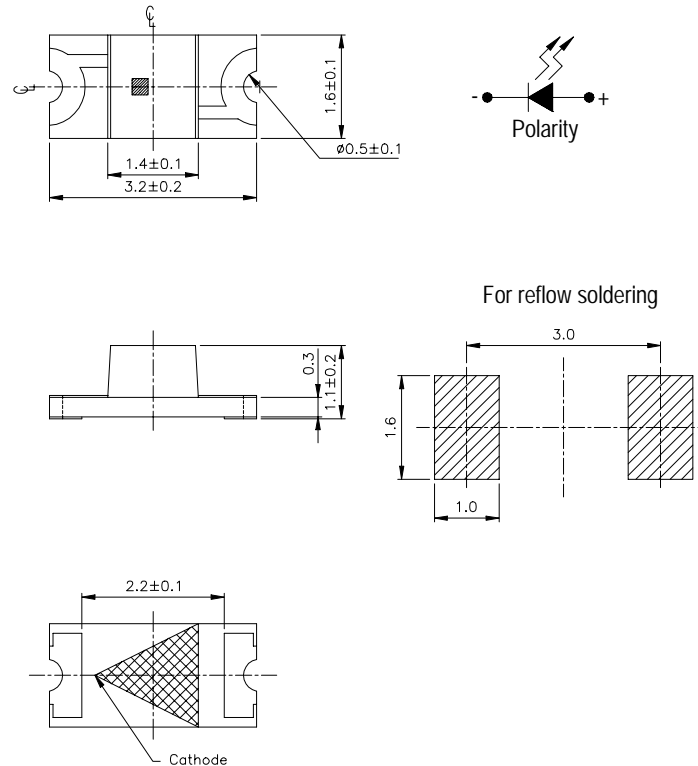

Notes: Tolerances Unless Dimension ± 0.1 mm , Angle $\pm 0.5^\circ$,Unit = mm

Absolute Maximum Ratings (Ta=25°C)

Parameter	Symbol	Rating	Unit
Reverse Voltage	V _R	5	V
Forward Current	I _F	30	mA
Operating Temperature	T _{opr}	-40 ~ +85	°C
Storage Temperature	T _{stg}	-40~ +90	°C
Soldering Temperature	T _{sol}	260 (for 5 second)	°C
Electrostatic Discharge	ESD	1000	V
Power Dissipation	P _d	130	mW
Peak Forward Current (Duty 1/10 @1KHz)	I _F	100	mA

23-21UBGC/TR8
Electro-Optical Characteristics (Ta=25°C)

Parameter	Symbol	Min.	Typ.	Max.	Unit	Condition
Luminous Intensity	I _v	60	130	-----	mcd	I _F =20 mA
Viewing Angle	2θ 1/2	-----	130	-----	deg	I _F =20mA
Peak Wavelength	λ _p	-----	502	-----	nm	I _F =20mA
Dominant Wavelength	λ _d	-----	505	-----	nm	I _F =20mA
Spectrum Radiation Bandwidth	Δλ	-----	30	-----	nm	I _F =20mA
Forward Voltage	V _F	-----	3.5	4.3	V	I _F =20mA
Reverse Current	I _R	-----	-----	50	μ A	V _R =5V

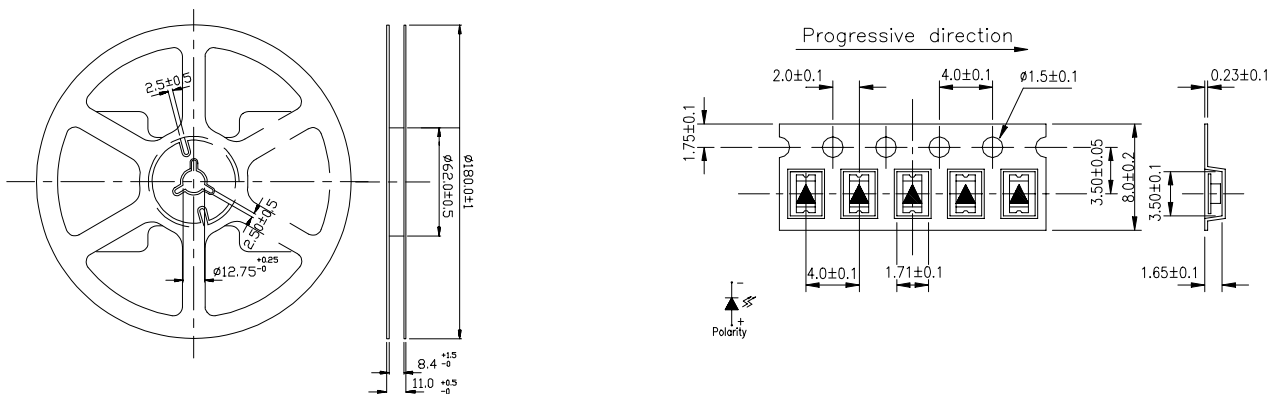
Reel & Carrier Tape Dimensions
Loaded quantity per reel 2000 PCS/reel

Notes: Tolerances Unless Dimension ± 0.1mm , Angle± 0.5° ,Unit = mm

Typical Electro-Optical Characteristics Curves

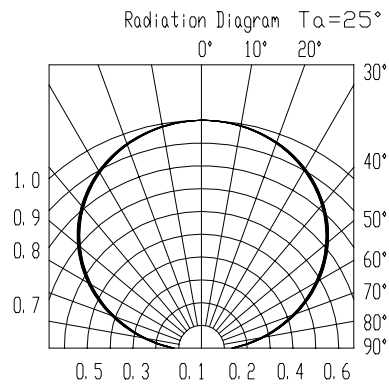
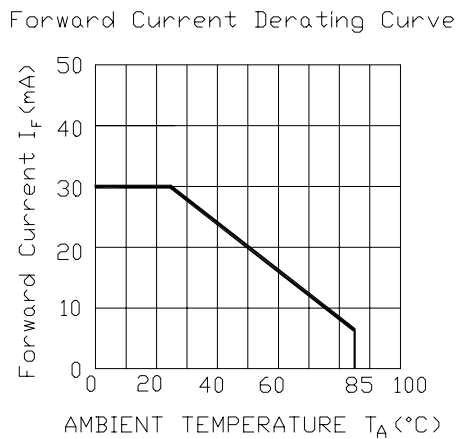
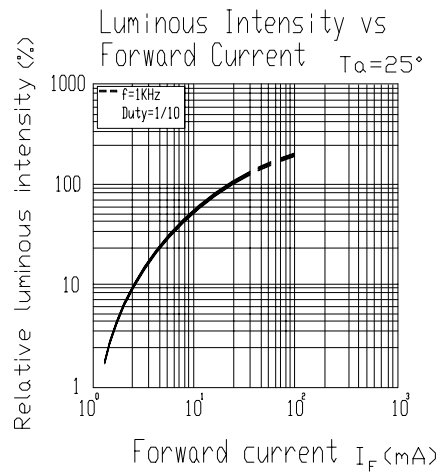
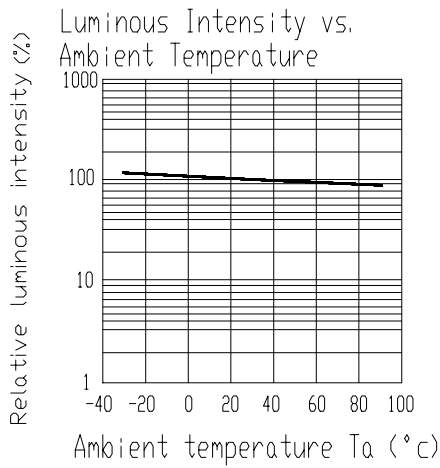
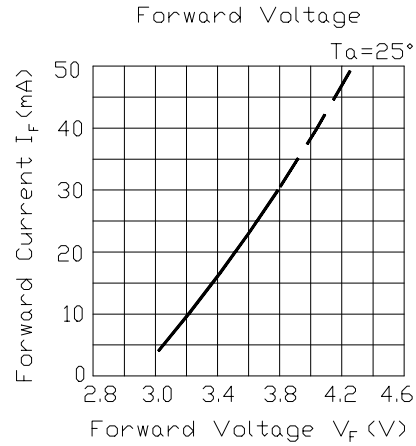
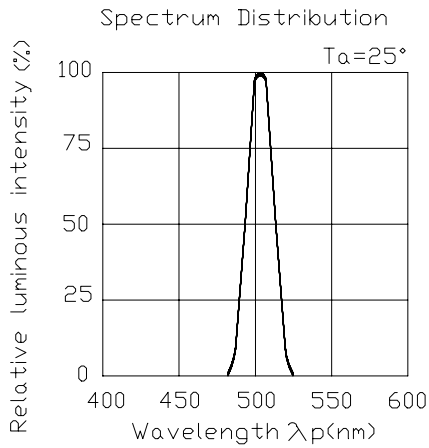

Reliability Test Items And Conditions

No.	Items	Test Condition	Test Hours/Cycles	Sample Size	Ac/Rc
1	Solder Heat	Temp. : 260°C ± 5°C	5 Sec.	76 PCS.	0/1
2	Temperature Cycle	H : +85°C 30min ∫ 5 min L : -55°C 30min	50 Cycles	76 PCS.	0/1
3	Thermal Shock	H : +100°C 5min ∫ 10 sec L : -10°C 5min	50 Cycles	76 PCS.	0/1
4	High Temperature Storage	Temp. : 100°C	1000 Hrs.	76 PCS.	0/1
5	Low Temperature Storage	Temp. : -55°C	1000 Hrs.	76 PCS.	0/1
6	DC Operating Life	I _F = 20 mA	1000 Hrs.	76 PCS.	0/1
7	High Temperature / High Humidity	85°C /RH85%	1000 Hrs.	76 PCS.	0/1

Precautions For Use

1. Over-current-proof

Customer must apply resistors for protection , otherwise slight voltage shift will cause big current change (Burn out will happen).

2. Storage time

2.1 The operation of Temperature and RH are : 5°C ~35°C , RH60%.

2.2 Once the package is opened, the products should be used within a week. Otherwise, they should be kept in a damp proof box with descanting agent. Considering the tape life , we suggest our customers to use our products within a year(from production date).

2.3 If opened more than one week in an atmosphere 5°C ~35°C , RH 60%, they should be treated at 60°C± 5°C for 15hrs.

2.4 When you discover that the desiccant in the package has a pink color (Normal = blue) , you should treat them in the same conditions as 2.3.

Soldering heat reliability (DIP)

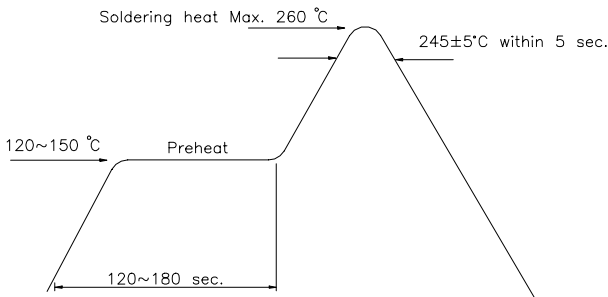

Reflow Temp / Time

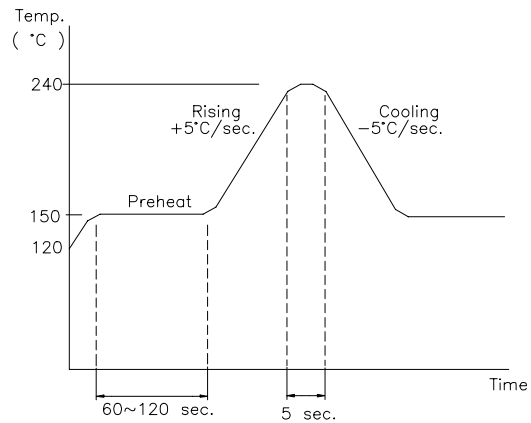

Soldering Iron

Basic spec is ≤ 5 sec when 260°C. If temperature is higher, time should be shorter (+10°C → -1sec). Power dissipation of Iron should be smaller than 15 W , and temperature should be controllable. Surface temperature of the device should be under 230 °C.

Rework

1. Customer must finish rework within 5 sec under 245°C.
2. The head of iron can not touch copper foil.
3. Twin-head type is preferred.

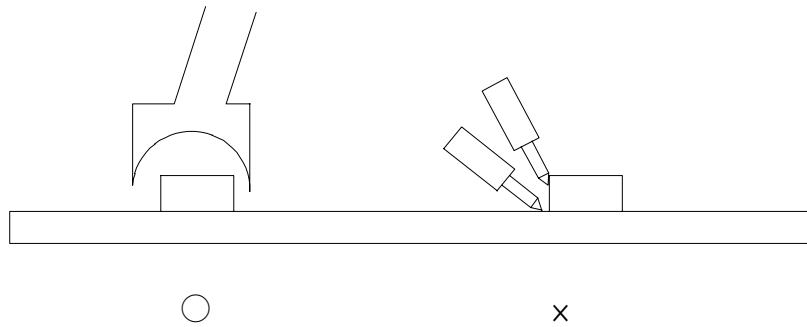
**EVERLIGHT ELECTRONICS CO., LTD.**

Office: No 25, Lane 76, Sec 3, Chung Yang Rd,
Tucheng, Taipei 236, Taiwan, R.O.C

Tel: 886-2-2267-2000, 2267-9936

Fax: 886-2267-6244, 2267-6189, 2267-6306

<http://www.everlight.com>