

UNCONTROLLED DOCUMENT

PART NUMBER
SSL-LX5573HD

REV.
B

REV.	E.C.N. NUMBER AND REVISION COMMENTS	DATE
A	E.C.N. #10684.	11.30.00
B	E.C.N. #11148	11.08.06

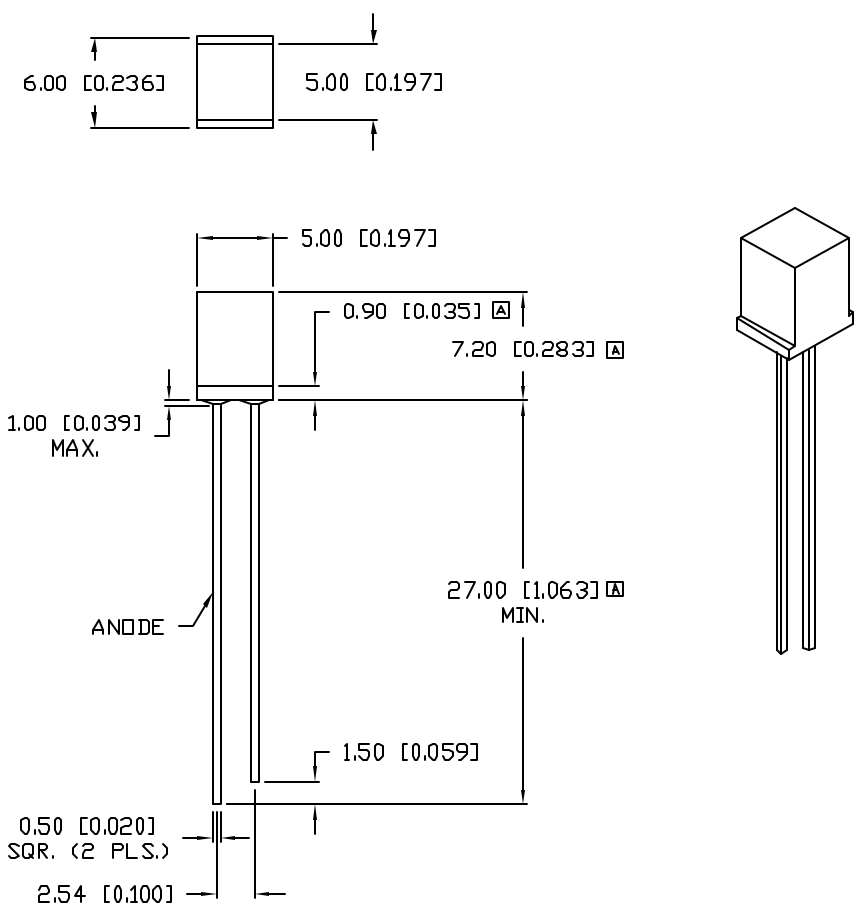

ELECTRO-OPTICAL CHARACTERISTICS $T_A=25^{\circ}\text{C}$ $I_f=20\text{mA}$

PARAMETER	MIN	TYP	MAX	UNITS	TEST COND
PEAK WAVELENGTH		695		nm	
FORWARD VOLTAGE		2.1	2.8	V_f	
REVERSE VOLTAGE	5.0			V_r	$I_f=100\mu\text{A}$
AXIAL INTENSITY		8		mcd	$I_f=20\text{mA}$
VIEWING ANGLE		110		2x theta	
EMITTED COLOR:	RED				
EPOXY LENS FINISH:	RED DIFFUSED				

LIMITS OF SAFE OPERATION AT 25°C

PARAMETER	MAX	UNITS
PEAK FORWARD CURRENT*	155	mA
STEADY CURRENT	30	mA
POWER DISSIPATION	110	mW
DERATE FROM 25°C	-1.2	mW/ $^{\circ}\text{C}$
OPERATING, STORAGE TEMP.	-40 TO +85	$^{\circ}\text{C}$
SOLDERING TEMP.	+260	$^{\circ}\text{C}$
2.0 mm FROM BODY		5 SEC. MAX

* $t < 10\mu\text{s}$



*UNLESS OTHERWISE SPECIFIED TOLERANCES PER DECIMAL PRECISION ARE: X=±1 (±0.039), X.X=±0.5 (±0.020), X.XX=±0.25 (±0.010), X.XXX=±0.127 (±0.005). LEAD SIZE=±0.05 (±0.002), LEAD LENGTH=±0.75 (±0.030). MIN= ^{+0.00} _{-0.00} DECIMAL PRECISION MAX.= ^{+0.00} _{-0.00} DECIMAL PRECISION

UNCONTROLLED DOCUMENT

REV. B	PART NUMBER SSL-LX5573HD
-----------	-----------------------------

CONFIDENTIAL INFORMATION
THE INFORMATION CONTAINED IN THIS DOCUMENT IS THE PROPERTY OF LUMEX INC. EXCEPT AS SPECIFICALLY AUTHORIZED IN WRITING BY LUMEX INC, THE HOLDER OF THIS DOCUMENT SHALL KEEP ALL INFORMATION CONTAINED HEREIN CONFIDENTIAL AND SHALL PROTECT SAME IN WHOLE OR IN PART FROM DISCLOSURE AND DISSEMINATION TO ALL THIRD PARTIES.



290 E. HELLEN ROAD
PALATINE, ILLINOIS 60067
PHONE: (847) 359-2790
WEB: <http://www.lumex.com>

5mm x 5mm SQUARE 695nm RED LED,
RED DIFFUSED LENS.

RELIABILITY NOTE
OUR MANY YEARS OF EXPERIENCE DATA ACCUMULATION INDICATE THAT SOLDER HEAT IS A MAJOR CAUSE OF EARLY AND FUTURE FAILURE. PLEASE PAY ATTENTION TO YOUR SOLDERING PROCESS.

DRAWN BY: JC	CHECKED BY:	APPROVED BY:	DATE: 11.08.06
			PAGE: 1 OF 1
			SCALE: N/A